



M-Series Operator's Manual

Mini-GPU for Experimental/Amateur-Built Aircraft



Model M1435-EXP
14-Volt 35-Amp Maximum Continuous

Thank you for your purchase!

Please **register your GPU** to activate your warranty and receive important software updates for your product.

Scan the QR code or go to www.audioauthority.com/register.

Your personal data is safe with us; we do not share your information.



REGISTER

IMPORTANT DISCLAIMERS & LIABILITY LIMITATIONS

As a condition for use, Audio Authority Corp. authorizes this device for use ONLY by aviation professionals, such as licensed pilots and maintenance technicians, knowledgeable about the aircraft's electrical system and batteries. Experimental/Amateur-Built aircraft electrical systems not only vary widely; they are unique. Many aircraft electrical systems also become altered from the original builder's configuration and these changes are often poorly documented in the aircraft records.

The concepts, recommendations, and instructions in this manual are necessarily general and make assumptions that do not apply to every aircraft and may not be correct for your particular aircraft. Incorrect use of this device has the potential to damage the GPU and/or aircraft components. This product also requires installation of electrical wiring to the airframe to function.

It is the operator's sole responsibility to read completely and fully understand this manual, plus all available documentation on their aircraft's electrical system design, to properly determine the appropriate use of this, or any, external power source. **If you cannot do this, do not use this product.** Instead, consult a qualified technician familiar with your specific aircraft type and configuration before connecting the GPU to your aircraft, or return it to the seller before using.

About the Manufacturer

Audio Authority Corp. has been building innovative aviation related products since 2006 including GPUs, battery charging harnesses and power receptacle installation kits. These products are proudly designed and assembled in Lexington, Kentucky. Audio Authority was established in 1976 as an audio equipment retail operation, but gradually shifted to engineering and manufacturing audio equipment and other electronic products. Jonathan Sisk, the Founder and CEO, has been a pilot for many years, and maintains a small passenger plane for company trips. You can learn more about our history, unique company culture, and other products at www.audioauthority.com.



General Description and Application

The Model M1435-EXP Mini-GPU is a specialized switching-mode power supply designed to provide pilots and aviation maintenance professionals with a portable, affordable source of stable, high-current, noise-free DC power that replicates the in-flight electrical environment. Its rated output is 14 Volts DC up to 35 amps maximum continuous current. It is designed specifically for the owner/operator/maintainer of Experimental/Amateur-Built (E/AB) aircraft. The GPU's intended purpose is to energize aircraft's main electrical bus without using the battery or engine. It will safely provide continuous power for the most delicate electronics and airframe systems up to its full rated output.

Typical Uses

- power avionics for flight planning, familiarization, and training
- update flight deck database and software
- troubleshooting and maintenance



Special Features

- Color-coded, keyed SB-50 type output connections to prevent accidental voltage mismatch (Yellow designates 12/14 volt compatibility)
- Dual digital output meters for voltage and current load
- Front panel status indicator LED
- Programmable auto-shutdown timer
- Dual USB power ports for mobile device charging
- QuietFiltered™ output for interference-free COM radio operation
- Auto protection/recovery from short circuit, reverse polarity, over voltage/load/temperature

Operating Conditions and Limitations

The M1435-EXP is internally fan-cooled and relies on unobstructed ventilation access for proper operation. The GPU should operate on a clean, hard surface so that debris cannot be ingested. Its design assumes a dry operating environment. If used outdoors, it is the operator's responsibility to ensure that the unit is not exposed to moisture.

The M1435-EXP is designed to provide **airframe power only**. It is not a battery charger. It does not monitor the state-of-charge of the aircraft battery. It is not suitable for engine starting. A *charged* aircraft battery of any chemistry may be safely used with the M1435-EXP. A discharged battery, if in-circuit with external power, may overload the GPU and engage its internal protection (see Troubleshooting).

Safety Precautions

- Do not use this or any electrical device near uncontained fuel or fuel vapors.
- Use in a well-ventilated area.
- Do not use in a wet environment.
- Disconnect GPU from aircraft when not in use.
- Do not leave unattended while in use.

Special Considerations for Experiment/Amateur-Built (E/AB) Aircraft

E/AB aircraft typically differ from certified aircraft in several important ways that affect providing electrical power for ground operations:

- E/A-B aircraft are generally smaller with less complex design and systems.
- Certified aircraft are usually designed with a triggered external power receptacle that routes electrical power directly to the airframe and/or engine while bypassing the battery. E/A-B builders do not usually include an external power receptacle in their electrical wiring to reduce expense.
- Certified aircraft must conform to their type design. E/AB aircraft have no type design conformity requirements and can differ significantly from one aircraft to another. Builders are free to design and build the aircraft to suit their individual preferences.

To use a GPU, most E/AB aircraft will need to install the provided wiring kit to create an easily accessible electrical connection to the aircraft's main electrical bus.

External Power Wiring Techniques and Diagrams

Best practice for wiring an external power receptacle, whether for battery maintenance charging or airframe power, is to wire to the battery contactor, NOT directly to the battery. There are two options as to which side of the contactor for making the connection, each with trade-offs to consider:

- 1) **CONTACTOR OUTPUT** – Wiring to the output side of the battery contactor provides direct access to the main bus for airframe power and bypasses the battery (unless the Battery Master Switch is ON).
- 2) **CONTACTOR INPUT** – Wiring to the input side of the contactor provides direct access to the battery and cannot energize the airframe (unless the Battery Master Switch is ON).

Option 1 is the most appropriate and preferred for GPU operations. It keeps the battery out of the power circuit unless desired and deliberately enabled by turning the Battery Master switch ON.

Option 2 may be considered if the operator wants to provide an electrical connection for both the GPU and a full-time maintenance type battery charger (e.g., BatteryMINDER®) from a single SB-50 plug. Option 2 also allows the GPU voltmeter to display no-load battery voltage when connected with the GPU power OFF. Some users may find this useful to assess the battery's state-of-charge.

Option 3, and the better approach if both GPU and maintenance charging are desired, is to install two separate SB-50 plugs, one to the battery side of the contactor for full-time maintenance charging; and another to the main bus side of the contactor for connecting a GPU for airframe power.

With E/AB aircraft it is ultimately the decision and at the sole discretion of the builder to evaluate the trade-offs for how and where to install in the receptacle(s) for GPU and/or battery charging in the aircraft. See the wiring diagrams below. The most common wiring scheme for external power receptacle is a shared connection for both battery charging and GPU airframe power, option diagram 2.

Wiring Diagrams for External Power Receptacle 12-Volt Experimental/Amateur-Built Aircraft

Option 1 – Output or Bus Side of Battery Contactor

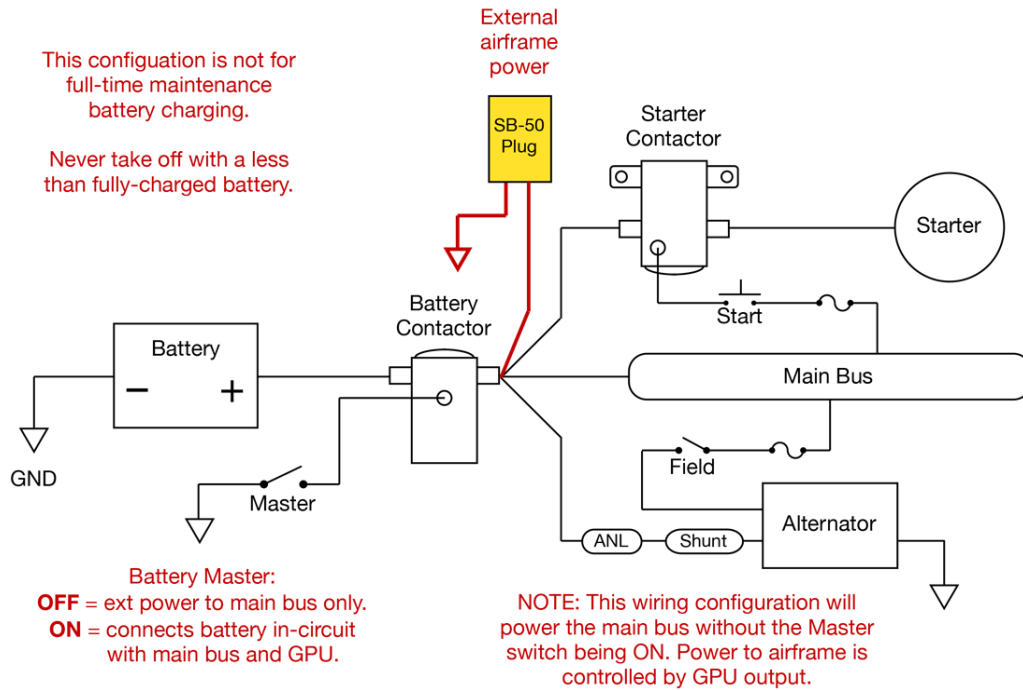

Option 2 – Input or Battery Side of Contactor

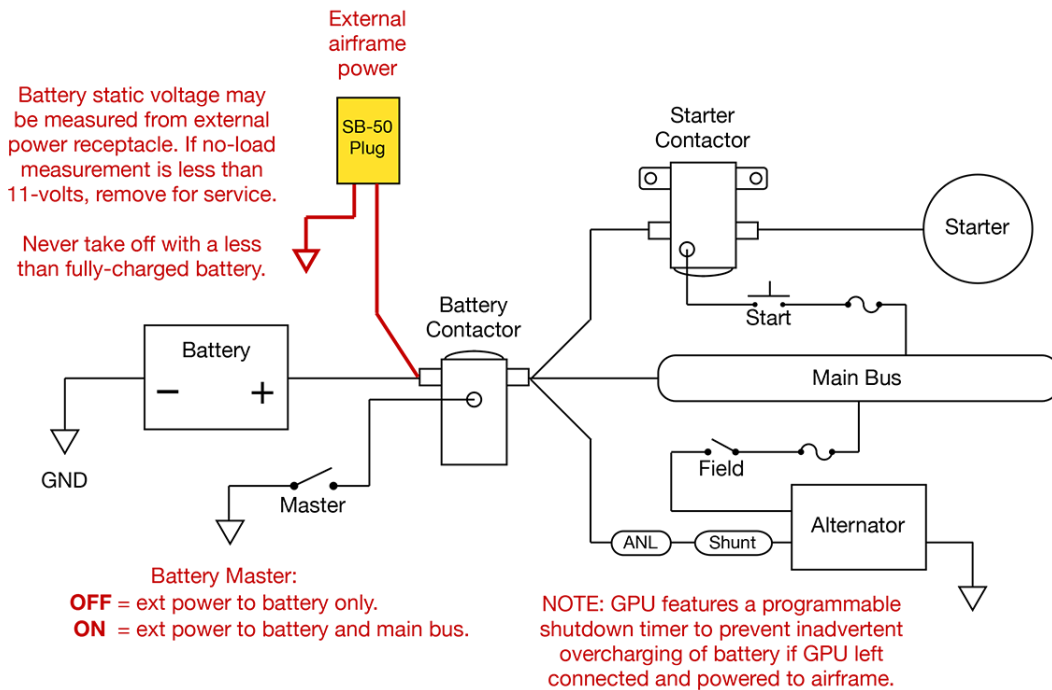

Installing the External Power Plug

- Locate a place near the battery contactor for the external power plug with convenient access, protected from heat and exposure, and permanently mount the SB-50 plug.
- Prepare two lengths of primary wire to connect the positive lug of the SB-50 plug to the battery contactor, and the negative lug to the airframe ground.
- Touch solder and install the connector lugs. Instructions are included with the wiring kit. It is recommended to install the included protective cover for the plug.
- Once the external power plug is installed, polarity tested and labeled, the GPU is ready to use.

Connecting GPU to Aircraft

- Connect the GPU AC input cord to a grounded power receptacle, 90-240VAC, 50-60Hz.
- Connect the output cable (dual 8-gauge cable with Yellow SB-50 plug on each end) to the GPU.
- Turn GPU power switch ON, observe as proper voltage stabilizes on the output display.
- Connect GPU output cable to SB-50 plug on the aircraft, observe that the airframe is energized and shows a stable load of less than 35 amps. If voltage or current load are not as expected, or GPU status indicator is flashing or red, disconnect the GPU from the airframe and investigate the problem.

SAFETY TIP: Using the GPU during preflight allows a thorough inspection of all systems and lights, without depleting the battery. In fact, if the battery is in-circuit, the GPU can provide a brief “top-off” charge for the aircraft battery!

Status Indicator

The GPU incorporates a status indicator between the volt/amp meter and the output connector. Indications are interpreted as follows:

- OFF** = Power Switch OFF, or no AC input power
- GREEN** = ON or powered, normal operation
- FLASHING GREEN** = Auto-shutdown engaged
- FLASHING RED** = Fault condition – see troubleshooting table for more details

Automatic Shutdown Timer

The M1435-EXP features a programmable timer to automatically shut down the GPU after a period of time in use, as selected by the user. This is to prevent the GPU from inadvertently being left on for an extended period and potentially overcharging the aircraft’s battery, if in-circuit with the GPU.

A 10-position rotary switch on the back panel determines the duration of continuous operation. Each number represents ½ hour. This switch is factory set at 5 (2.5 hours); adjust with a small screwdriver. To disable the auto-shutdown feature, set the switch to the 0 position.

To reset the timer and restart the GPU after auto-shutdown, cycle the power switch OFF then back ON.

USB Mobile Device Charging

Two convenience USB charging ports are provided on the rear panel of the GPU. These provide a 5VDC output, up to 2A total combined, suitable for charging many portable devices like phones and speakers.

Troubleshooting

PROBLEM / CONDITION	CAUSE	SOLUTION
GPU does not turn ON Volt/Amp meter OFF Status indicator OFF	No AC input to GPU.	Verify power cord connections. Check AC input fuse. If blown, replace (only once). 1 extra fuse is contained in the fuse drawer. If fuse blows a second time, do not replace until GPU is repaired. See Limited Warranty statement for technical service contact information.
GPU displays voltage but no output to aircraft (zero amps) Status indicator GREEN	Faulty connection between GPU and aircraft electrical system.	Check connections from GPU to the aircraft's external power receptacle.
Volt/amp meter OFF Status indicator FLASHING GREEN	Auto-shutdown timer expired.	Cycle power switch OFF, then back ON, to restart shutdown timer. Adjust timer settings if desired, or zero to disable shutdown timer.
Status indicator FLASHING RED Voltage drops to < 13 volts	Current overload.	Reduce load to less than 35 amps.
Status indicator FLASHING RED Volt/Amp meter OFF	Internal protection engaged. Over temperature, or Sustained overload.	Reduce load to less than 35 amps. Turn off aircraft equipment to reduce current draw. Cycle Power Switch OFF then ON again to reset.
Status indicator FLASHING RED GPU displays voltage but no output to aircraft (zero amps)*	Internal protection engaged.	If cable connections are good, then turn power switch OFF. Disconnect DC output cord from aircraft external power receptacle. Wait for GPU meter to go OFF. Power switch ON. Meter ON. Reconnect to aircraft.

* In certain instances, battery voltage backfeeding from the aircraft may trigger protection mode in the GPU, thereby preventing normal power up. Follow instructions above for disconnecting from the aircraft and resetting the GPU to restore proper operation.

SPECIFICATIONS	
Input	90-240 Volts AC, 50-60 Hz, 5.3A @ 115VAC
Input fuse	8A Littelfuse 617 Series. P/N 0617008.MXP
Output	14.25 +/- 0.25 Volts DC, 35 amps maximum continuous
Output cable	8 AWG dual conductor, SB-50 plug each end, yellow (12/14V)
Chassis dimensions	4.13" H x 5.32" W x 13.4" L
Carry weight	9.5 lbs., cables included
Carton dimensions	6" H x 10" W x 16" L
Shipping weight	11 lbs

Operating Tip

Connecting a GPU, any GPU, to some aircraft may automatically energize certain airframe systems (like motors for air conditioning or hydraulics) that could cause an overload condition. A sustained overload will cause the GPU to self-protect and shutdown. To restore GPU operation, disconnect it from the aircraft and cycle the power switch to reset its internal protection. To prevent the overload condition, identify and pull the circuit breakers that control those devices, then reconnect the GPU.

A similar overload may be encountered if a partially discharged battery is used in-circuit with the GPU's output. In this case, the GPU's response to the battery may exceed either the its maximum charging rate and voltage, or the GPU's capability, causing an overload protective shutdown.

CAUTION: While a fully charged battery of any chemistry may be safely used in-circuit with a GPU, a discharged battery should always be removed from the aircraft for bench charging. It is the aircraft owner's responsibility to follow the battery manufacturer's instructions for charging and capacity testing the battery for airworthiness before reinstalling and/or using it in-circuit with a GPU.

One Year Limited Warranty

Model M1435-EXP Mini-GPUs are warranted to the original purchaser to be free of defects in materials and workmanship for a period of one year from date of shipment. If you suspect a failure, please contact our service department for instructions or see our Service Policies online at www.audioauthority.com/page/Service_policy.

Service Department
Audio Authority Corporation
2048 Mercer Road, Lexington, KY 40511
Phone: 800-322-8346 (or 859-233-4599)
Email: support@audioauthority.com

Units received that are in-warranty will be repaired without charge. Units returned for service require a return authorization number and must be shipped freight prepaid. Units repaired under warranty will be returned freight prepaid via UPS ground or equivalent. A repair estimate will be provided for out-of-warranty repairs. This warranty is void for products that, in our opinion, have been subject to overload, moisture, accident, damage, alteration, misuse, abuse, or acts of nature.

THE SOLE AND EXCLUSIVE REMEDY UNDER THIS WARRANTY IS LIMITED TO REPAIR OR REPLACEMENT AS SPECIFIED ABOVE. THERE ARE NO OTHER WARRANTIES EXPRESSED OR IMPLIED. SPECIFICALLY, BUT WITHOUT LIMITATION, THERE ARE NO IMPLIED WARRANTIES OF MERCHANTABILITY OR FITNESS FOR A PARTICULAR PURPOSE. IN NO EVENT WILL AUDIO AUTHORITY BE RESPONSIBLE FOR ANY INCIDENTAL OR CONSEQUENTIAL DAMAGES ARISING FROM ANY DEFECT, OR FAILURE TO OPERATE PROPERLY, OR ARISING OUT OF ANY BREACH OF THE WARRANTY MADE HEREIN.

No person is authorized to give any other warranty or to assume any additional obligation or liability on behalf of Audio Authority Corporation, without its express written approval.



Audio Authority Corp. 2048 Mercer Road, Lexington, KY 40511 Phone: 800-322-8346 or 859-233-4599
support@audioauthority.com www.AudioAuthority.com/aviation